



# SPECIFICATION SHEET

## PVE 2804

Excavator Mounted Vibratory Hammer



**PVE EQUIPMENT USA**

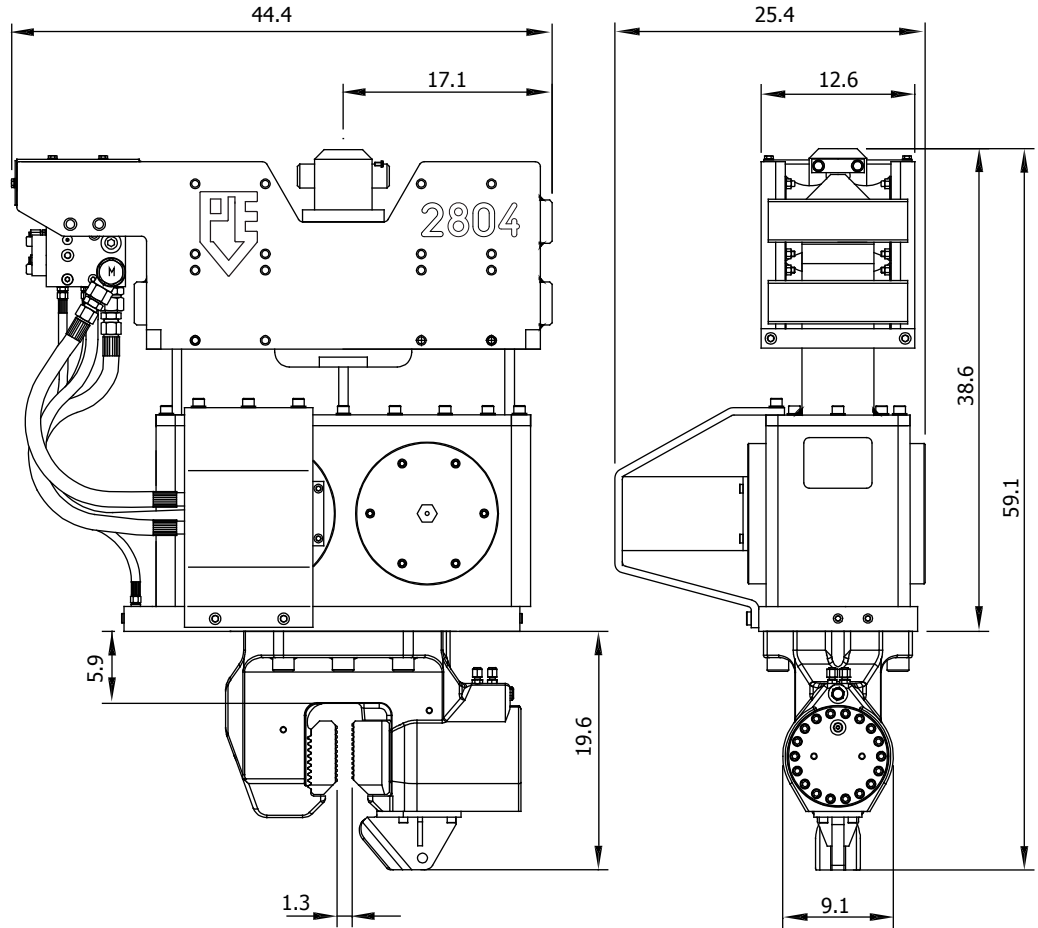

Dimensions in inches

## TECHNICAL SPECIFICATIONS

Specifications	2804	
Eccentric moment	399	inch-lbs
Max. centrifugal force	44	tons
Max. frequency	2800	vpm
Max. amplitude *)	0.55	inch
Max. static line pull	13	tons
Max. oil flow	44	gpm
Dynamic weight *)	1433	lbs
Total weight *)	1984	lbs
L x W x H *)	44 x 25 x 39	inch
Recommended clamp	DWK 60TU	

*\*) excluding clamp*

**PVE Equipment USA Inc.** P. O. Box 12529 5011 Vernon Road Jacksonville, FL 32209, USA  
 T 904 765 6686 W pve-equipment.com

Member of the **DIESEKO GROUP**