



## Specifications\*

### Energy Per Blow, Adjustable

Pump Setting 1	64 %	171.1 / 126,180	kNm / ft-lbs
Pump Setting 2	74 %	196.7 / 145,100	kNm / ft-lbs
Pump Setting 3	89 %	239.8 / 176,840	kNm / ft-lbs
Pump Setting 4	100 %	267.3 / 197,150	kNm / ft-lbs
Frequency		36...45	blows/min
Related Piston Stroke		3.4...2.1 / 11.1...7.1	m / ft.

Maximum batter w/o upper cyl. ext.	1:5	-
with upper cylinder extension	1:1	-
Fuel consumption at full load	25.0 / 6.60	L/hr. / gal./hr.
Oil consumption	2.6 / 0.68	L/hr. / gal./hr.

### Approx. Weights

Hammer	16907 / 37,275	kg / lbs.
Piston	8000 / 17,640	kg / lbs.
Hammer with standard guiding	18690 / 41,200	kg / lbs.

### Capacities

Fuel Tank	155 / 40.9	L / gal.
Oil Tank	32 / 8.4	L / gal.

### Dimensions

<b>A</b>	- Length	7195 / 23.6	mm / ft.
<b>LH</b>	- Length, standard	8565 / 28.1	mm / ft.
<b>B</b>	- Center to trip	660 / 26.0	mm / in.
<b>C</b>	- Center to pump guard	584 / 23.0	mm / in.
<b>D</b>	- Width of hammer	890 / 35.0	mm / in.
<b>D1</b>	- Width of trip	1206 / 47.5	mm / in.
<b>W</b>	- Minimum lead width	1067 / 42.0	mm / in.

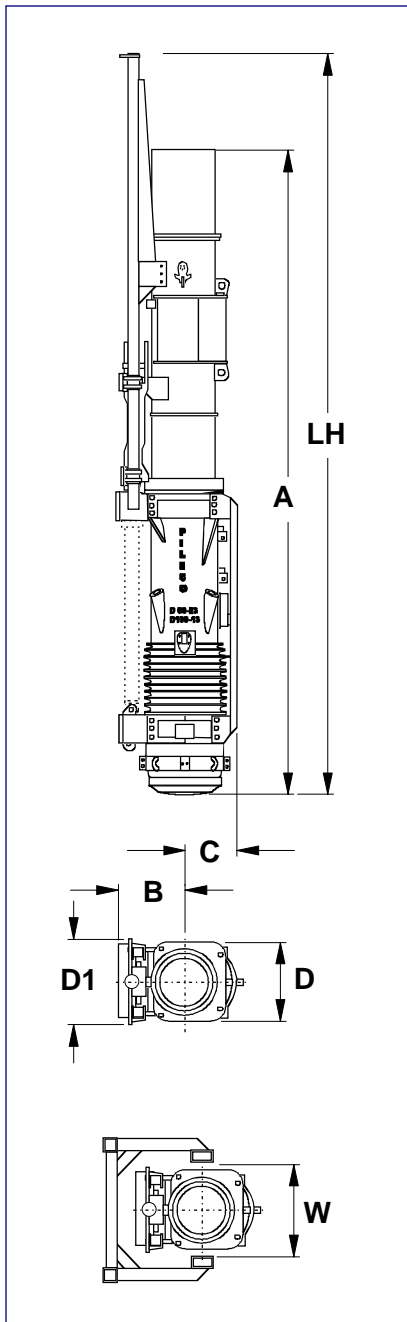

\*September 21, 2006 Technical data are subject to change without prior notice  
 Operating energy based on piston stroke – values are approximate.  
 Hydraulic start optional.

**Pileco, Inc.**

P.O. Box 16099 Houston, Texas 77222 USA – Tel. (713) 691-3000 – Facsimile No. (713) 691-0089  
 E-mail: pileco@pileco.com – <http://www.pileco.com> Call Toll Free 1-800-231-0421