



Specifications

Energy Per Blow, Adjustable*

Pump Setting 1	50 %	107.4 / 79,200	kNm / ft-lbs
Pump Setting 2	66 %	145.7 / 107,490	kNm / ft-lbs
Pump Setting 3	83 %	181.9 / 134,160	kNm / ft-lbs
Pump Setting 4	100 %	219.2 / 161,640	kNm / ft-lbs
Frequency		35...50	blows/min
Related Piston Stroke		3.6...1.7 / 11.8...5.7	m / ft.

Maximum batter w/o upper cyl. ext.	1:5	-
with upper cylinder extension	1:1	-
Fuel consumption at full load	20.0 / 5.28	L/hr. / gal./hr.
Oil consumption	2.0 / 0.53	L/hr. / gal./hr.

Approx. Weights

Hammer	12282 / 27,077	kg / lbs.
Piston	6200 / 13,670	kg / lbs.
Hammer with standard guiding	13290 / 29,300	kg / lbs.

Capacities

Fuel Tank	98 / 25.8	L / gal.
Oil Tank	31 / 8.3	L / gal.

Dimensions

A	- Length	6890 / 22.6	mm / ft.
LH	- Length, standard	7560 / 24.8	mm / ft.
	- Length with hydraulic start	7864 / 25.8	mm / ft.
B	- Center to trip	508 / 20.0	mm / in.
B1	- Center to trip with cylinder	686 / 27.0	mm / in.
C	- Center to pump guard	648 / 25.5	mm / in.
D	- Width of hammer	825 / 32.5	mm / in.
D1	- Width of trip	902 / 35.5	mm / in.
W	- Minimum lead width	812 / 32.0	mm / in.

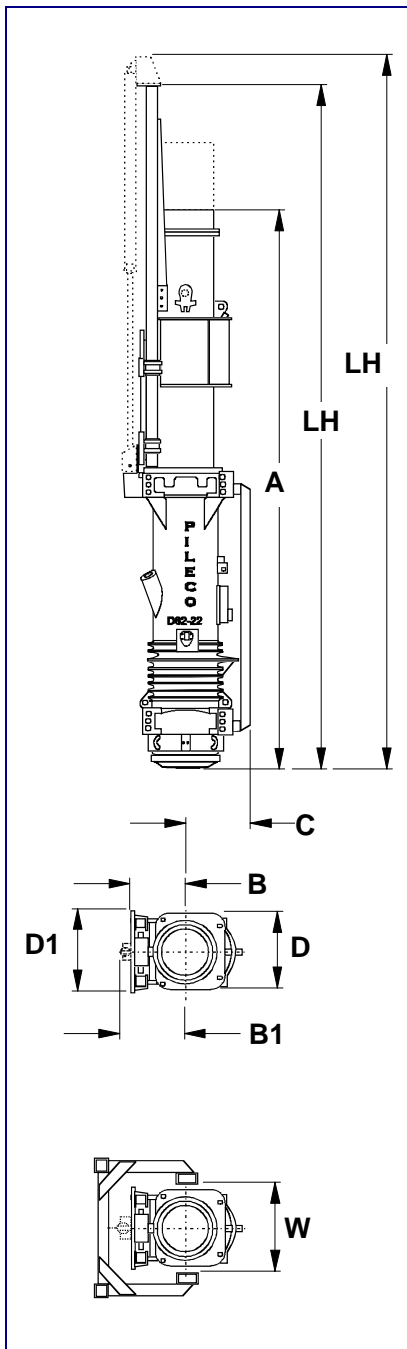

**September 21, 2006 Technical data are subject to change without prior notice
 Operating energy based on piston stroke – values are approximate.
 Hydraulic start and upper cylinder extension optional.*

Pileco, Inc.

P.O. Box 16099 Houston, Texas 77222 USA – Tel. (713) 691-3000 – Facsimile No. (713) 691-0089
 E-mail: pileco@pileco.com – <http://www.pileco.com> Call Toll Free 1-800-231-0421