



## Specifications\*

### Energy Per Blow, Adjustable

Pump Setting 1	49 %	73.7 / 54,320	kNm / ft-lbs
Pump Setting 2	66 %	96.0 / 70,805	kNm / ft-lbs
Pump Setting 3	83 %	120.7 / 89,040	kNm / ft-lbs
Pump Setting 4	100 %	145.5 / 107,280	kNm / ft-lbs
Frequency		37...52	blows/min
Related Piston Stroke		3.2...1.6 / 10.5...5.3	m / ft.

Maximum batter w/o upper cyl. ext.	1:5	-
with upper cylinder extension	1:1	-
Fuel consumption at full load	16.0 / 4.23	L/hr. / gal./hr.
Oil consumption	1.5 / 0.39	L/hr. / gal./hr.

### Approx. Weights

Hammer	8888 / 19,580	kg / lbs.
Piston	4600 / 10,145	kg / lbs.
Hammer with standard guiding	10025 / 22,100	kg / lbs.

### Capacities

Fuel Tank	89 / 23.5	L / gal.
Oil Tank	17 / 4.5	L / gal.

### Dimensions

<b>A</b>	- Length	5580 / 18.3	mm / ft.
<b>LH</b>	- Length, standard	6490 / 21.3	mm / ft.
	- Length with hydraulic start	6860 / 22.5	mm / ft.
<b>B</b>	- Center to trip	482 / 19.0	mm / in.
<b>B1</b>	- Center to trip with cylinder	660 / 26.0	mm / in.
<b>C</b>	- Center to pump guard	521 / 20.5	mm / in.
<b>D</b>	- Width of hammer	724 / 28.5	mm / in.
<b>D1</b>	- Width of trip	940 / 37.0	mm / in.
<b>W</b>	- Minimum lead width	812 / 32.0	mm / in.

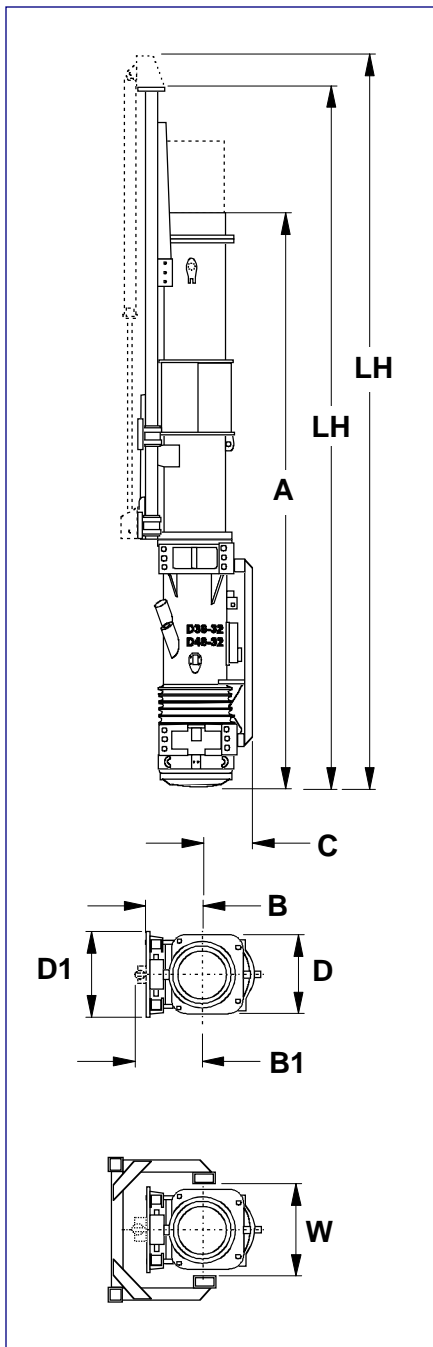

\*September 21, 2006 Technical data are subject to change without prior notice  
 Operating energy based on piston stroke – values are approximate.  
 Hydraulic start and upper cylinder extension optional.

**Pileco, Inc.**

P.O. Box 16099 Houston, Texas 77222 USA – Tel. (713) 691-3000 – Facsimile No. (713) 691-0089  
 E-mail: pileco@pileco.com – <http://www.pileco.com> Call Toll Free 1-800-231-0421