



Specifications*

Energy Per Blow, Adjustable

Pump Setting 1	49%	57.6 / 42,500	kNm / ft-lbs
Pump Setting 2	66%	75.1 / 55,410	kNm / ft-lbs
Pump Setting 3	83%	94.5 / 69,680	kNm / ft-lbs
Pump Setting 4	100%	113.8 / 83,950	kNm / ft-lbs
Blow Count		37...52	blows/min
Related Piston Stroke		3.2...1.6 / 10.5...5.3	m / ft.

Maximum batter w/o upper cyl. extension	1:5	-
with upper cylinder extension	1:1	-
Fuel consumption at full load	11.5 / 3.04	L/hr. / gal./hr.
Oil consumption	1.5 / 0.39	L/hr. / gal./hr.

Approx. Weights

Hammer	7880 / 17,375	kg / lbs.
Piston	3600 / 7,940	kg / lbs.
Hammer with standard guiding	9026 / 19,900	kg / lbs.

Capacities

Fuel Tank	89 / 23.5	L / gal.
Oil Tank	17 / 4.5	L / gal.

Dimensions

A	- Length	5580 / 18.3	mm / ft.
LH	- Length, standard	6490 / 21.3	mm / ft.
	- Length with hydraulic start	6860 / 22.5	mm / ft.
B	- Center to trip	482 / 19.0	mm / in.
B1	- Center to trip with cylinder	660 / 26.0	mm / in.
C	- Center to pump guard	521 / 20.5	mm / in.
D	- Width of hammer	724 / 28.5	mm / in.
D1	- Width of trip	940 / 37.0	mm / in.
W	- Minimum width of U-lead	812 / 32.0	mm / in.

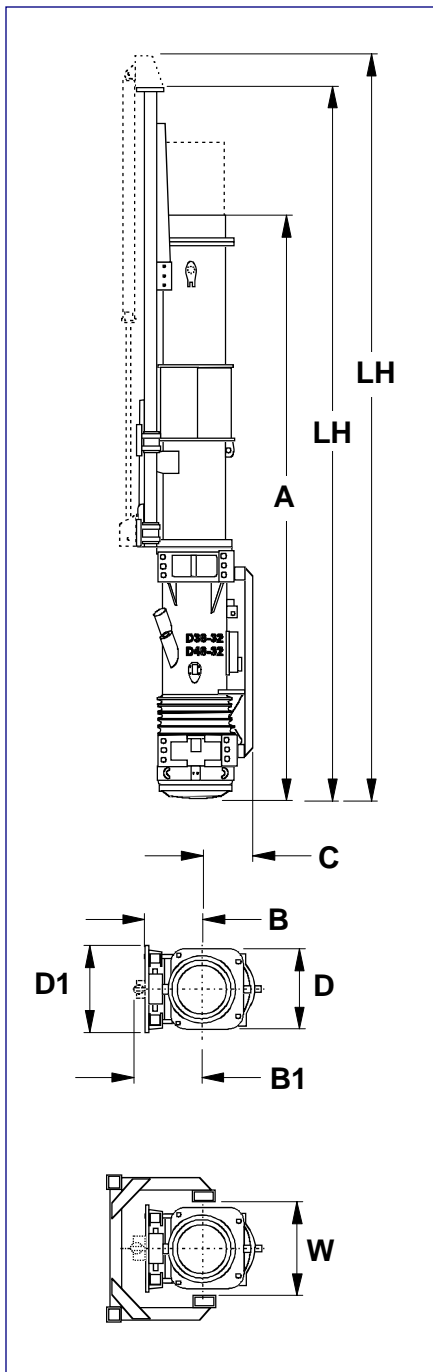

* September 21, 2006 Technical data are subject to change without prior notice
 Operating energy based on piston stroke – values are approximate.
 Hydraulic start optional.

Pileco, Inc.

P.O. Box 16099 Houston, Texas 77222 USA – Tel. (713) 691-3000 – Facsimile No. (713) 691-0089
 E-mail: pileco@pileco.com – <http://www.pileco.com> Call Toll Free 1-800-231-0421