



## Specifications\*

### Energy Per Blow, Adjustable

Pump Setting 1	50 %	40.0 / 29,510	kNm / ft-lbs
Pump Setting 2	74 %	58.5 / 38,830	kNm / ft-lbs
Pump Setting 3	90 %	71.1 / 52,470	kNm / ft-lbs
Pump Setting 4	100 %	79.0 / 58,300	kNm / ft-lbs
Frequency		35...50	blows/min
Related Piston Stroke		3.6...1.7 / 11.8...5.7	m / ft.

Maximum batter w/o upper cyl. ext.	1:5	-
with upper cylinder extension	1:1	-
Fuel consumption at full load	8.0 / 2.11	L/hr. / gal./hr.
Oil consumption	1.0 / 0.26	L/hr. / gal./hr.

### Approx. Weights

Hammer	5610 / 12,370	kg / lbs.
Piston	2500 / 5,515	kg / lbs.
Hammer with standard guiding	6710 / 14,800	kg / lbs.

### Capacities

Fuel Tank	67 / 17.7	L / gal.
Oil Tank	19 / 5.0	L / gal.

### Dimensions

<b>A</b>	- Length	5425 / 17.8	mm / ft.
<b>LH</b>	- Length, standard	6490 / 21.3	mm / ft.
	- Length with hydraulic start	6860 / 22.5	mm / ft.
<b>B</b>	- Center to trip	445 / 17.5	mm / in.
<b>B1</b>	- Center to trip with cylinder	610 / 24.0	mm / in.
<b>C</b>	- Center to pump guard	482 / 19.0	mm / in.
<b>D</b>	- Width of hammer	635 / 25.0	mm / in.
<b>D1</b>	- Width of trip	812 / 32.0	mm / in.
<b>W</b>	- Minimum lead width	660 / 26.0	mm / in.

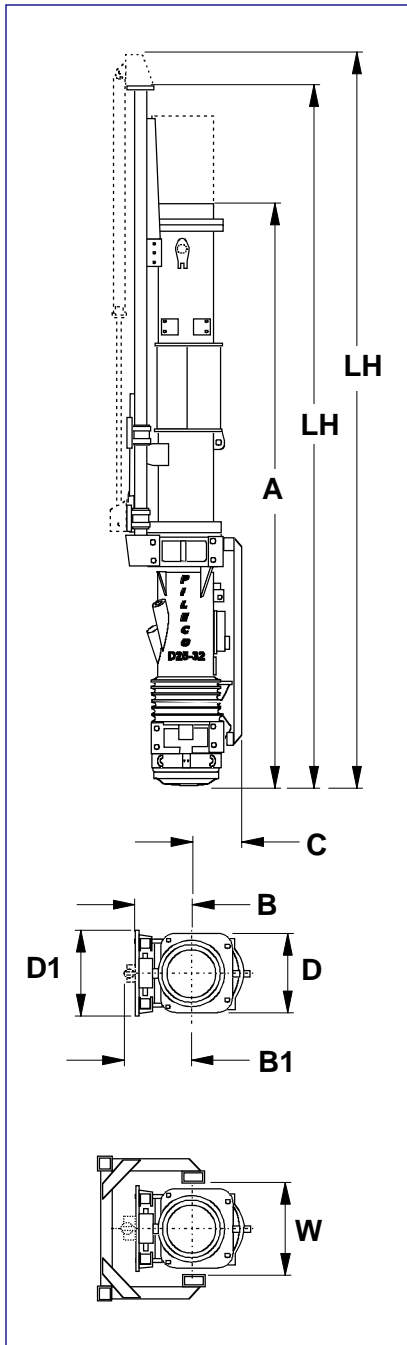

\*September 21, 2006 Technical data are subject to change without prior notice  
 Operating energy based on piston stroke – values are approximate.  
 Hydraulic start and upper cylinder extension optional.

**Pileco, Inc.**

P.O. Box 16099 Houston, Texas 77222 USA – Tel. (713) 691-3000 – Facsimile No. (713) 691-0089  
 E-mail: pileco@pileco.com – <http://www.pileco.com> Call Toll Free 1-800-231-0421